

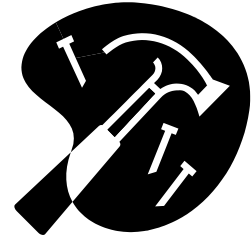

DECK PERMIT APPLICATION

Building Department
25 LaGrange Street
Newnan, GA 30263
Ph. 770-254-2362 Fax 770-254-2361
Email – BuildingPlans@cityofnewnan.org



Subject Property

Address: _____

Number and Street

Subdivision

Name and Contact #: _____

Name

Contact Phone Number

Submission Checklist:

Site plan signed by Planning and Zoning

(House location plat usually included in your closing documents or obtains from court house)

Plan drawings checklist:

- Overall deck size, include height from grade
- Beam size and spacing
- Ledgerboard size (show flashing and throughbolts)
- Post size and location
- Footing size, depth, and connection
- Joist size and spacing
- Joist connections (hangers)
- Size of decking
- Size and spacing of guardrail posts
- Size and spacing of pickets
- Height of guardrail
- Stair location and pad
- Cantilever if applicable

Inspections

- Footing – before concrete is placed
- Framing – before decking is installed (only if deck is less than 3 feet from grade)
- Final – after entire deck is completed

Estimated cost of project: _____

I understand that I am to phone in all inspections for this project, and will be responsible for complying with all construction codes as adopted by the State of Georgia DCA.

Signature of Owner Occupant

Date

Prescriptive Residential Deck Construction Guide

Based on the *2006 International Residential Code*

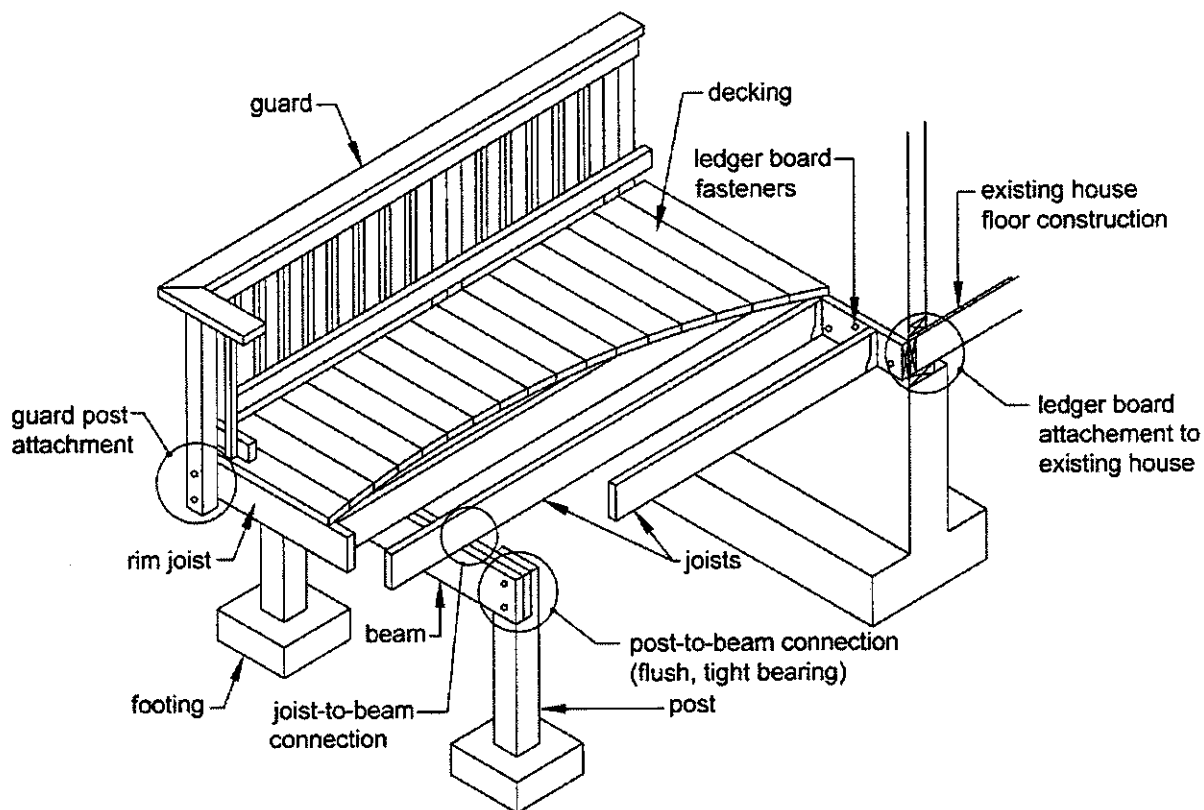

WHERE APPLICABLE, PROVISIONS AND DETAILS CONTAINED IN THIS DOCUMENT ARE BASED ON THE *INTERNATIONAL RESIDENTIAL CODE (IRC)* [bracketed text shows reference to applicable sections of the *IRC*]. PROVISIONS CONTAINED IN THIS DOCUMENT THAT ARE NOT INCLUDED IN THE *IRC* ARE CONSIDERED GOOD PRACTICE RECOMMENDATIONS. WHERE DIFFERENCES OCCUR BETWEEN PROVISIONS OF THIS DOCUMENT AND THE *IRC*, THE PROVISIONS OF THE *IRC* SHALL APPLY.

CONTENTS

| | | | |
|--|----|---------------------------------------|----|
| MINIMUM REQUIREMENTS..... | 2 | PROHIBITED LEDGER ATTACHMENTS..... | 12 |
| DECKING REQUIREMENTS..... | 3 | LEDGER BOARD FASTENERS..... | 12 |
| JOIST SIZE..... | 3 | FREE-STANDING DECKS..... | 14 |
| BEAM SIZE & ASSEMBLY REQUIREMENTS..... | 5 | DECK STABILITY..... | 14 |
| DECK FRAMING PLAN..... | 6 | GUARD REQUIREMENTS..... | 15 |
| JOIST-TO-BEAM CONNECTION..... | 7 | GUARD POST ATTACHMENTS..... | 16 |
| JOIST HANGERS..... | 7 | STAIR REQUIREMENTS..... | 17 |
| POST REQUIREMENTS..... | 7 | STAIR HANDRAIL REQUIREMENTS..... | 18 |
| RIM JOIST REQUIREMENTS..... | 8 | STAIR FOOTING REQUIREMENTS..... | 19 |
| FOOTINGS..... | 9 | STAIR LIGHTING REQUIREMENTS..... | 19 |
| LEDGER ATTACHMENT REQUIREMENTS..... | 10 | FRAMING AT CHIMNEY OR BAY WINDOW..... | 19 |

MINIMUM REQUIREMENTS

1. This document applies to single level residential decks only.
2. All lumber shall be identified by the grade mark of, or certificate of inspection issued by, an approved lumber grading or inspection bureau or agency (www.alsc.org). All lumber shall be a naturally durable species (such as Redwood or Western Cedars) or be pressure-treated with an approved process and preservative in accordance with American Wood Protection Association standards (Table 1). All lumber in contact with the ground shall be rated as “ground-contact.” [R319.1 and R320.3.1]
3. All nails shall meet the requirements of *ASTM F 1667*. Wood screws shall meet the requirements of *ANSI/ASME Standard B18.6.1*. Bolts and lag screws shall meet the requirements of *ANSI/ASME B18.2.1*.
4. To resist corrosion, the following is required [R319.3]:
 - All screws, bolts, and nails shall be hot-dipped galvanized, stainless steel, silicon bronze or copper. Fasteners to be hot-dipped galvanized shall meet the requirements of *ASTM A 153, Standard Specification for Zinc Coating (Hot-Dip) on Iron and Steel Hardware*, Class D for fasteners $\frac{3}{8}$ " in diameter and smaller or Class C for fasteners with diameters over $\frac{3}{8}$ ".
 - Fasteners other than nails and timber rivets shall be permitted to be of mechanically deposited zinc-coated steel with coating weights in accordance with *ASTM B 695, Class 55*, minimum.
 - All hardware (joist hangers, cast-in-place post anchors, etc.) shall be galvanized or shall be stainless steel. Hardware to be hot-dipped prior to fabrication shall meet *ASTM A 653, Standard Specification for Steel Sheet, Zinc-Coated (Galvanized) or Zinc-Iron Alloy-Coated (Galvannealed) by the Hot-Dip Process*, G-185 coating. Hardware to be hot-dipped galvanized after fabrication shall meet *ASTM A123, Specification for Zinc (Hot-Dip Galvanized) Coatings on Iron and Steel Products*.
 - Fasteners and connectors exposed to, and located within 300 feet of, a salt water shoreline shall be stainless steel grade 304 or 316.
 - Other coated or non-ferrous fasteners or hardware shall be as approved by the building official.
5. Decks supporting hot tubs are beyond the scope of this document.
6. This document does not apply to decks which will experience snow loads, snow drift loads, or sliding snow loads that exceed 40 psf. This document does not address lateral loads on decks such as wind or seismic.
7. Flashing shall be corrosion-resistant metal of minimum nominal 0.019-inch thickness or approved non-metallic material [R703.8].
8. Decks shall not be used or occupied until final inspection and approval is obtained.

Table 1. Common preservative treatments and retention levels (pcf) for sawn lumber in ground contact.^a

| Species | ACQ-B | ACQ-C | ACQ-D | CA-B | CuN-W |
|-------------------|-------|-------|-------|------|-------|
| Southern Pine | 0.40 | 0.40 | 0.40 | 0.21 | 0.11 |
| Douglas Fir-Larch | 0.40 | 0.40 | NR | 0.21 | 0.11 |
| Hem-Fir | 0.40 | 0.40 | 0.40 | 0.21 | 0.11 |
| Spruce-Pine-Fir | NR | 0.40 | NR | NR | NR |
| Redwood | NR | NR | NR | NR | NR |

^a Unless otherwise indicated, preservatives and retentions listed in Table 1 are based upon the American Wood Protection Association (AWPA) *Book of Standards*. NR = Treatments Not Recommended.

DECKING REQUIREMENTS

All decking material shall be composed of dimension lumber (2" nominal thickness) or span rated decking in accordance with the American Lumber Standard Committee *Policy for Evaluation of Recommended Spans for Span Rated Decking Products (November 5, 2004)*. Attach decking to each joist with 2-8d common nails or 2-#8 screws. Space decking boards approximately 1/8" apart. See Figure 11 for decking connection requirements at the rim joist. Decking may be placed from an angle perpendicular to the joists to an angle of 45 degrees to the joists. Each segment of decking must bear on a minimum of 4 joists.

Decking not meeting the above requirements may be substituted when the product has been approved by the authority having jurisdiction.

5/4 x 6 treated decking is allowable where the joist spans do not exceed 16" on center

JOIST SIZE

The span of a joist is measured from the centerline of bearing at one end of the joist to the centerline of bearing at the other end of the joist and does not include the length of the overhangs. Use Table 2 to determine joist span based on lumber size and joist spacing. See Figure 1 and Figure 2 for joist span types.

Table 2. Maximum Joist Spans¹

| Species | Size | Joist Spacing (o.c.) | | |
|--|------|----------------------|----------|-----------|
| | | 12" | 16" | 24" |
| Southern Pine | 2x8 | 10' - 6" | 10' - 6" | 10' - 2" |
| | 2x10 | 15' - 2" | 15' - 2" | 13' - 1" |
| | 2x12 | 18' - 0" | 18' - 0" | 15' - 5" |
| Douglas Fir-Larch, Hem-Fir, SPF ² | 2x8 | 9' - 3" | 9' - 3" | 9' - 1" |
| | 2x10 | 13' - 4" | 13' - 4" | 11' - 1" |
| | 2x12 | 17' - 10" | 15' - 9" | 12' - 10" |
| Redwood, Western Cedars | 2x8 | 8' - 4" | 8' - 4" | 8' - 4" |
| | 2x10 | 12' - 0" | 12' - 0" | 11' - 3" |
| | 2x12 | 16' - 1" | 16' - 0" | 13' - 0" |

1. Assumes 40 psf live load, 10 psf dead load, L/180 cantilever deflection with 230 lb point load, No. 2 grade, and wet service conditions. See span calculator at www.awc.org for simple span conditions without cantilevers.

2. Incising factor used for refractory species including Douglas fir-larch, hem-fir, and spruce-pine-fir.

Figure 1A: Joist Span – Deck Attached at House

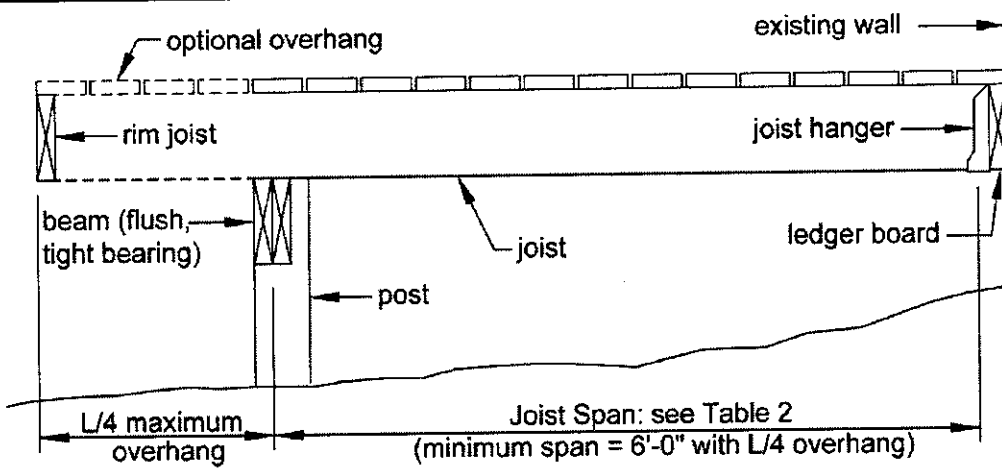

Figure 1B: Joist Span – Joists Attached to Side of Beam

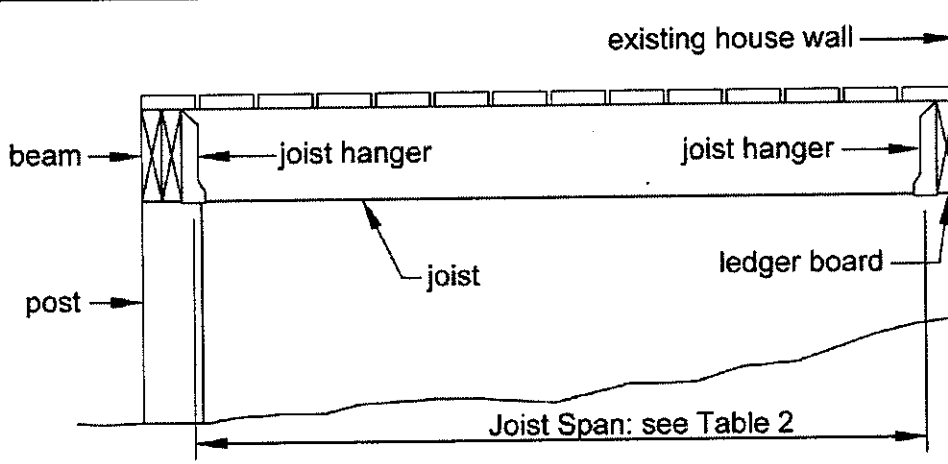
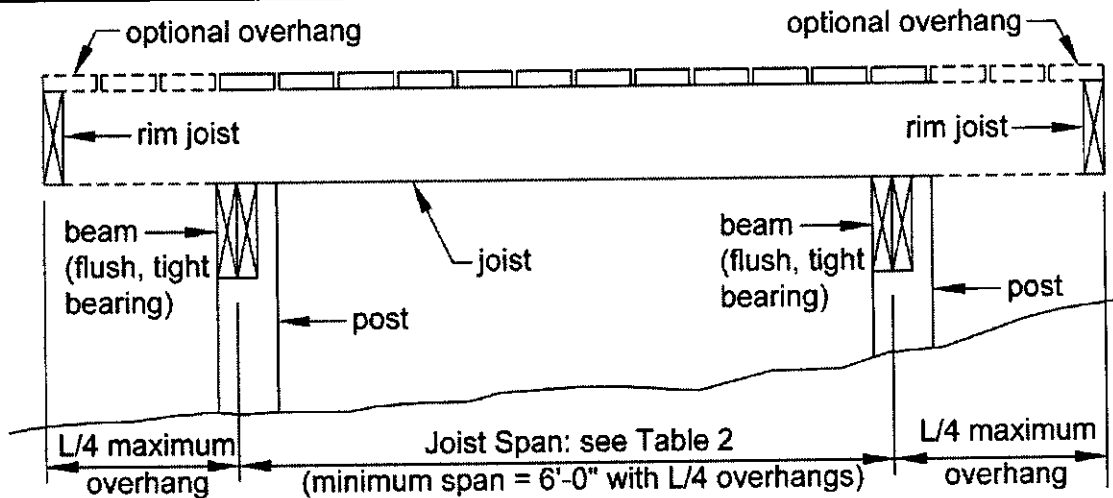

Figure 2: Joist Span – Free Standing Deck



BEAM SIZE & ASSEMBLY REQUIREMENTS

Deck beam spans shall be in accordance with Table 3 and can extend past the post centerline up to L/4 as shown in Figure 3. Joists may bear on the beam and extend past the beam centerline up to L/4 as shown in Figures 1A and 2, or the joists may attach to the side of the beam with joist hangers as shown in Figure 1B

(however, joists shall not be attached to opposite sides of the same beam). See JOIST-TO-BEAM CONNECTION details, Figure 6.

Where multiple 2x members are used, the deck's beam is assembled by attaching the members identified in Table 3 in accordance with Figure 4. [R602.3(1)]

Table 3. Deck Beam Spans¹

| Species | Size | Joist Spans (ft) Less Than or Equal to: | | | | | | |
|--|----------------|---|-----------|----------|----------|----------|----------|----------|
| | | 6 | 8 | 10 | 12 | 14 | 16 | 18 |
| Southern Pine | 2-2x6 | 7' - 1" | 6' - 2" | 5' - 6" | 5' - 0" | 4' - 8" | 4' - 4" | 4' - 1" |
| | 2-2x8 | 9' - 2" | 7' - 11" | 7' - 1" | 6' - 6" | 6' - 0" | 5' - 7" | 5' - 3" |
| | 2-2x10 | 11' - 10" | 10' - 3" | 9' - 2" | 8' - 5" | 7' - 9" | 7' - 3" | 6' - 10" |
| | 2-2x12 | 13' - 11" | 12' - 0" | 10' - 9" | 9' - 10" | 9' - 1" | 8' - 6" | 8' - 0" |
| | 3-2x6 | 8' - 7" | 7' - 8" | 6' - 11" | 6' - 3" | 5' - 10" | 5' - 5" | 5' - 2" |
| | 3-2x8 | 11' - 4" | 9' - 11" | 8' - 11" | 8' - 1" | 7' - 6" | 7' - 0" | 6' - 7" |
| | 3-2x10 | 14' - 5" | 12' - 10" | 11' - 6" | 10' - 6" | 9' - 9" | 9' - 1" | 8' - 7" |
| | 3-2x12 | 17' - 5" | 15' - 1" | 13' - 6" | 12' - 4" | 11' - 5" | 10' - 8" | 10' - 1" |
| Douglas Fir-Larch ² , Hem-Fir ² , SPF ² , Redwood, Western Cedars | 3x6 or 2-2x6 | 5' - 8" | 4' - 11" | 4' - 4" | 4' - 0" | 3' - 8" | 3' - 5" | 3' - 0" |
| | 3x8 or 2-2x8 | 7' - 2" | 6' - 2" | 5' - 6" | 5' - 0" | 4' - 8" | 4' - 4" | 4' - 0" |
| | 3x10 or 2-2x10 | 8' - 9" | 7' - 7" | 6' - 9" | 6' - 2" | 5' - 8" | 5' - 4" | 5' - 0" |
| | 3x12 or 2-2x12 | 10' - 1" | 8' - 9" | 7' - 10" | 7' - 2" | 6' - 7" | 6' - 2" | 5' - 10" |
| | 4x6 | 6' - 8" | 5' - 9" | 5' - 2" | 4' - 9" | 4' - 4" | 4' - 1" | 3' - 10" |
| | 4x8 | 8' - 9" | 7' - 7" | 6' - 10" | 6' - 3" | 5' - 9" | 5' - 5" | 5' - 1" |
| | 4x10 | 10' - 9" | 9' - 4" | 8' - 4" | 7' - 7" | 7' - 1" | 6' - 7" | 6' - 3" |
| | 4x12 | 12' - 6" | 10' - 10" | 9' - 8" | 8' - 10" | 8' - 2" | 7' - 8" | 7' - 3" |
| | 3-2x6 | 7' - 4" | 6' - 8" | 6' - 2" | 5' - 9" | 5' - 4" | 5' - 0" | 4' - 8" |
| | 3-2x8 | 9' - 8" | 8' - 9" | 7' - 11" | 7' - 3" | 6' - 9" | 6' - 3" | 5' - 11" |
| 3-2x10 | 12' - 4" | 10' - 10" | 9' - 8" | 8' - 10" | 8' - 2" | 7' - 8" | 7' - 3" | |
| 3-2x12 | 14' - 6" | 12' - 7" | 11' - 3" | 10' - 3" | 9' - 6" | 8' - 11" | 8' - 5" | |

1. Assumes 40 psf live load, 10 psf dead load, L/360 simple span beam deflection limit, L/180 cantilever deflection limit, No. 2 grade, and wet service conditions.
2. Incising factor used for refractory species including Douglas fir-larch, hem-fir, and spruce-pine-fir.

Figure 3: Beam Span Types

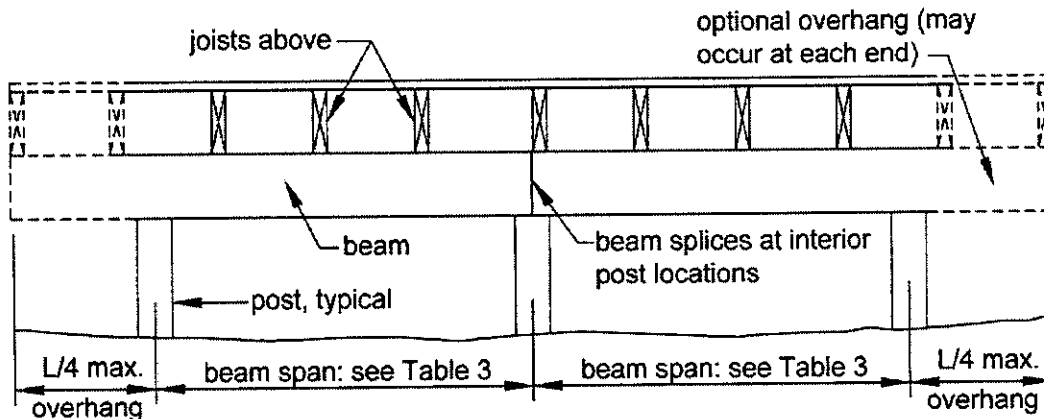
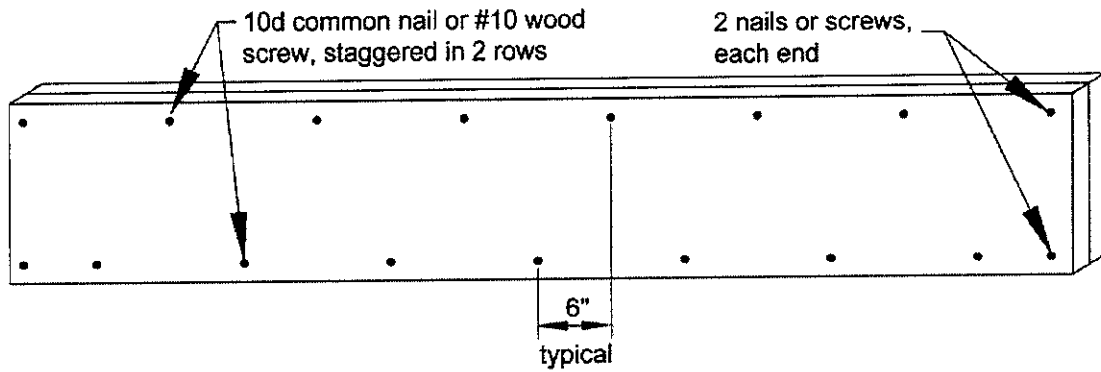

Figure 4: Beam Assembly Details



DECK FRAMING PLAN

A framing plan shows the joist and beam layout; the location of the ledger board, posts, and footings, and the type, size, and spacing of the ledger board fasteners. See Figure 5 for an example of a typical deck framing plan.

Figure 5: Typical Deck Framing Plan

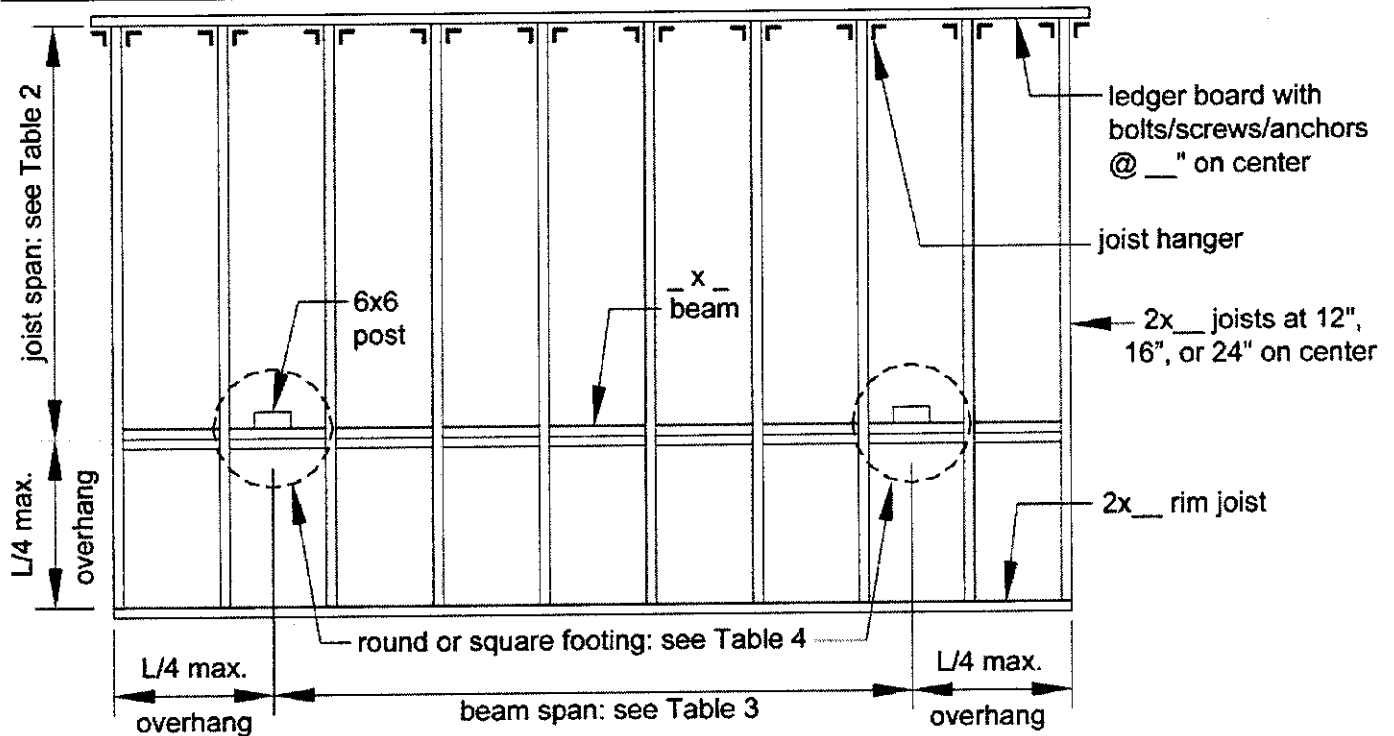

JOIST-TO-BEAM CONNECTION

Each joist shall be attached to the beam as shown in Figure 6. Joists may bear on and overhang past the beam a maximum of L/4. Use Option 1 or Option 2 to attach the joist to the beam. Option 1 shall only be used if the deck is attached to the house with a ledger (see LEDGER ATTACHMENT REQUIREMENTS) or as

shown in Figure 23. Joists may also attach to the side of the beam with joist hangers (however, joists shall not be attached to opposite sides of the same beam). See JOIST HANGERS for more information. Hangers, clips, and mechanical fasteners shall be galvanized (see MINIMUM REQUIREMENTS).

Figure 6: Joist-to-Beam Detail

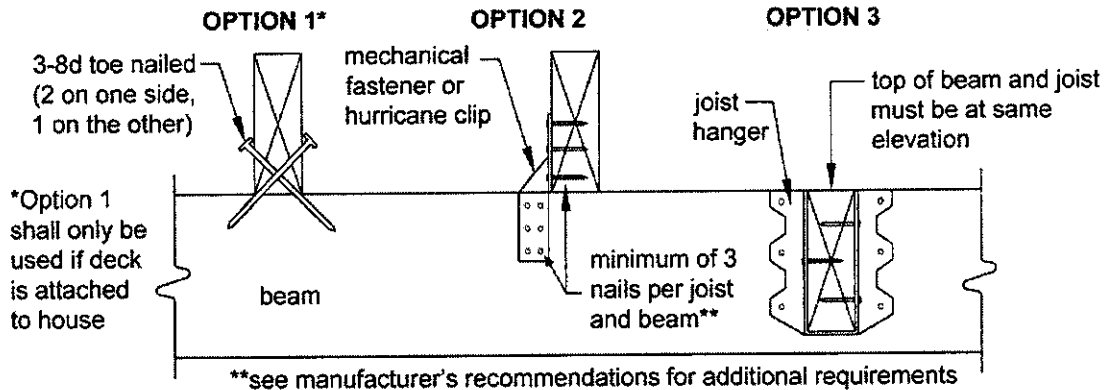

JOIST HANGERS

Joist hangers, as shown in Figure 7, shall each have a minimum capacity of 800 lbs. The joist hanger shall be selected from an approved manufacturer's product data based on the dimensions of the joist or header it is carrying. Joist hangers shall be galvanized (see MINIMUM REQUIREMENTS).

Use joist hangers with inside flanges when clearances to the edge of the beam or ledger board dictate. **Do not use clip angles or brackets to support joists.**

Figure 7: Typical Joist Hangers

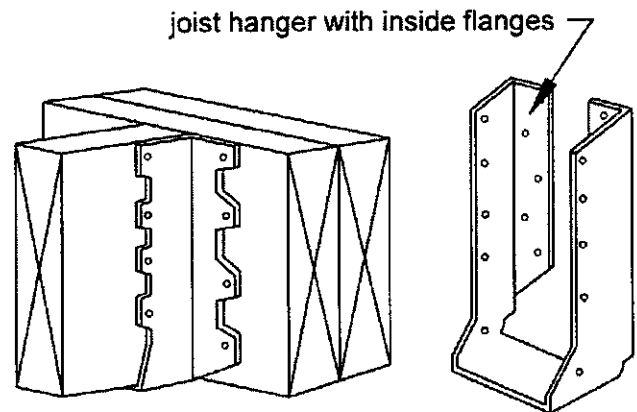

POST REQUIREMENTS [R407]

All deck post sizes shall be 6x6 (nominal) or larger, and the maximum height shall be 14'-0". Posts shall be centered on footings. Cut ends of posts shall be field treated with an approved preservative. The beam shall be attached to the post by notching the 6x6 as shown in Figure 8 or by providing an approved column cap to

connect the beam and post as shown in Figure 10. All 3-ply beams shall be connected to the post by a column cap. All thru-bolts shall have washers at the bolt head and nut. Attachment of the beam to the side of the post without notching is prohibited (see Figure 9).

4x4 posts are allowed to a height not greater than 10 feet

Figure 8: Post-to-Beam Attachment Requirements

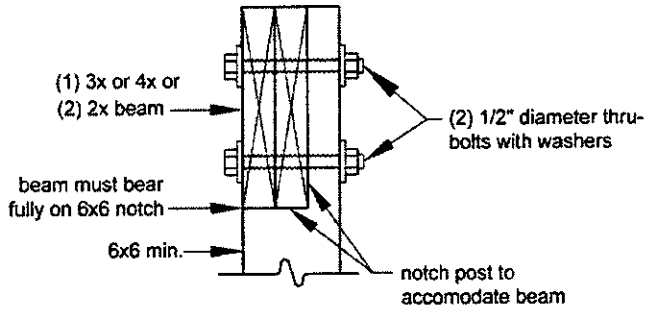
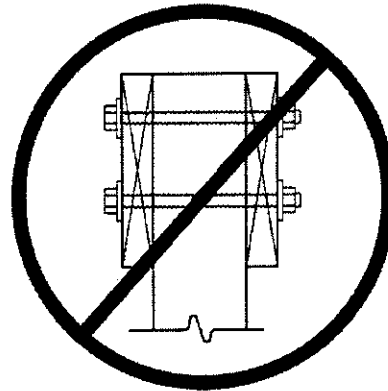

Figure 9: Prohibited Post-to-Beam Attachment Condition



RIM JOIST REQUIREMENTS

Attach a continuous rim joist to the ends of joists as shown in Figure 11. Attach decking to the rim joist as shown in Figure 11. For more decking attachment requirements, see DECKING REQUIREMENTS.

Figure 10: Alternate Approved Post-to-Beam Column Cap Attachment

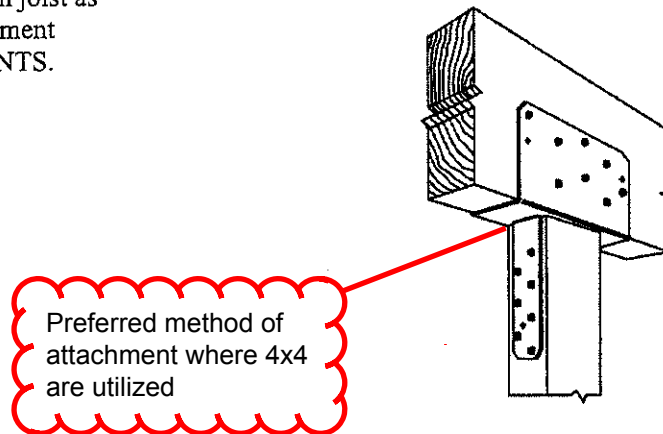
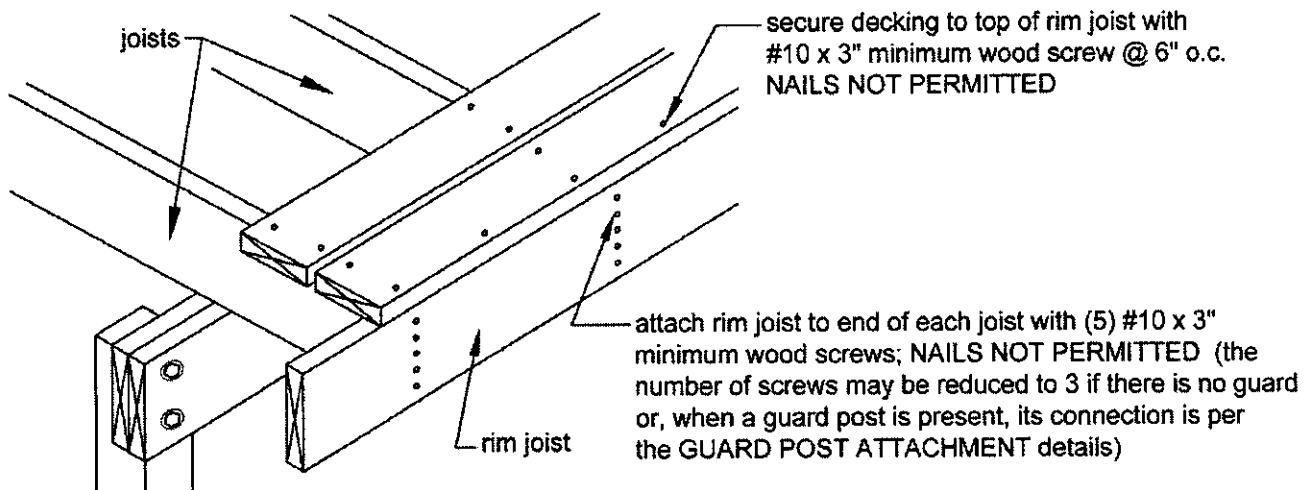

Figure 11: Rim Joist Connection Details



FOOTINGS [R403]

See Figure 12 and Table 4 for footing size, footing thickness, and post attachment options and requirements. All footings shall bear on solid ground and shall be placed at least 12 inches below the undisturbed ground surface or below the frost line, whichever is deeper; bearing conditions shall be verified in the field by the building official prior to placement of concrete. Where the building official determines that in-place soils with an allowable bearing capacity of less than 1,500 psf are likely to be present at the site, the allowable bearing capacity shall be determined by a soils investigation. DECK FOOTINGS CLOSER THAN 5'-0" TO AN EXISTING EXTERIOR HOUSE WALL MUST BEAR AT THE SAME ELEVATION AS THE FOOTING OF THE EXISTING HOUSE FOUNDATION.

Do not construct footings over utility lines or enclosed meters. Call the local utilities before digging.

Pre-manufactured post anchors shall be galvanized. See MINIMUM REQUIREMENTS.

TABLE 4. FOOTING SIZES²

| Beam Span | Joist Span | Round ¹ Footing Diameter | Footing Thickness ³ |
|-----------|------------|-------------------------------------|--------------------------------|
| 6' | <10' | 15" | 6" |
| | <14' | 17" | 6" |
| | <18' | 20" | 7" |
| 8' | <10' | 17" | 6" |
| | <14' | 20" | 7" |
| | <18' | 23" | 9" |
| 10' | <10' | 19" | 7" |
| | <14' | 22" | 9" |
| | <18' | 25" | 10" |
| 12' | <10' | 21" | 8" |
| | <14' | 24" | 10" |
| | <18' | 28" | 11" |
| 14' | <10' | 22" | 9" |
| | <14' | 26" | 11" |
| | <18' | 30" | 12" |
| 16' | <10' | 24" | 9" |
| | <14' | 28" | 11" |
| | <18' | 32" | 13" |

1. Square footings are permitted to have widths 2" less than the given diameter of round footings.
2. Assumes 1,500 psf soil bearing capacity.
3. Assumes 2,500 psf compressive strength of concrete. Coordinate footing thickness with post base and anchor requirements.

Minimum footing thickness shall be 8" or thicker, if required by table 4. Reinforcement of 2-#4 rebars, both directions is highly recommend and may be required based upon the size and height of the deck

Figure 12: Typical Footing Options

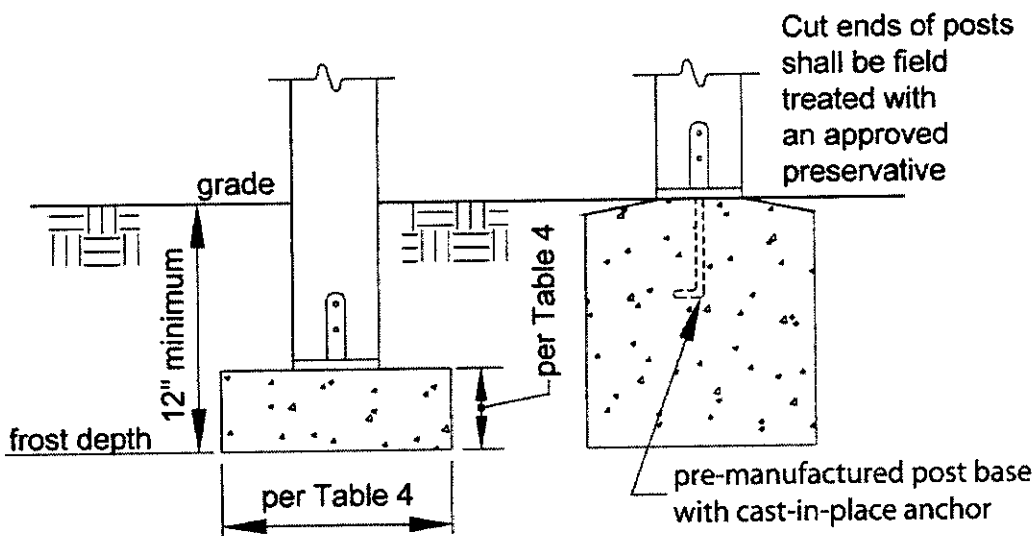

Posts must be anchored to footings. "Embedding" posts directly into footing is acceptable, however, minimum size and thickness of footing may need to be increased to ensure structural integrity of connection

LEDGER ATTACHMENT REQUIREMENTS [R502.2.1]

GENERAL: Attach the ledger board, which shall be equal to or greater than the joist size, to the existing exterior wall in accordance with Figure 14 through Figure 16. When attachments are made to the existing house band joist, the band joist shall be capable of supporting the new deck. If this cannot be verified or conditions at the existing house differ from the details herein, then either a free-standing deck or full plan submission is required. See **FREE-STANDING DECKS**.

SIDING AND FLASHING: House siding, or the exterior finish system, must be removed prior to installation of the ledger board. Approved corrosion resistant flashing is required at any ledger board connection to a wall of wood framed construction (see **MINIMUM REQUIREMENTS**). See Figure 14 for continuous flashing with drip edge.

MANUFACTURED WOOD JOIST: The term “I-Joist” denotes manufactured wood “I” joists (see Figure 13A). Many new homes constructed with wood I-joists include 1” or thicker engineered wood products (EWP) – such as oriented strand board (OSB) or structural composite lumber (SCL) including laminated veneer

lumber (LVL) – as band joists (or rim boards) that can support the attachment of a deck (see Figure 14). However, some older homes might be constructed with band boards that are too thin (3/4” or thinner) to support a deck. In such cases, a free-standing deck or a full plan submission is required.

MANUFACTURED WOOD TRUSS: A metal plate connected wood truss (MPCWT) is an engineered, prefabricated structural component designed for each specific application. MPCWT’s used in residential floors are often installed with a 2x4 lumber “ribbon” at the ends of the trusses (see Figure 13B), the purpose of which is to tie the ends of the trusses together. The ribbon board, by itself, is not intended to support the deck ledger and deck. Installing residential decks when the floor system for the house uses MPCWT requires a standard detail provided by the truss designer, a free-standing deck, or a full plan submission. Refer to the WTCA Technical Note – *Attachment of Residential Decks to Wood Truss Floor Systems* for special blocking details and attachment requirements (www.sbcindustry.com).

Figure 13A: Wood I-Joist Profile

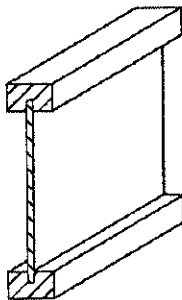

Figure 13B: Metal Plate Connected (MPC) Wood Floor Trusses with a 2x4 Lumber “Ribbon” at the Ends of the Trusses

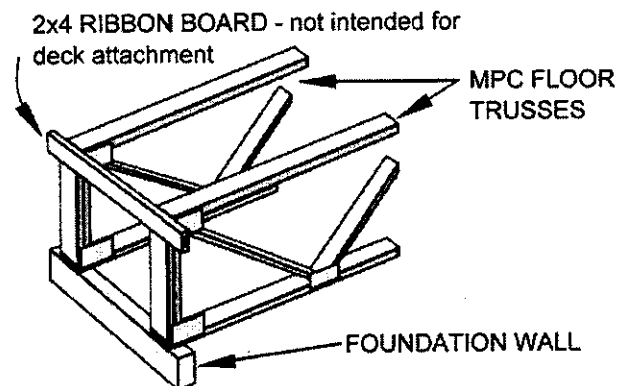
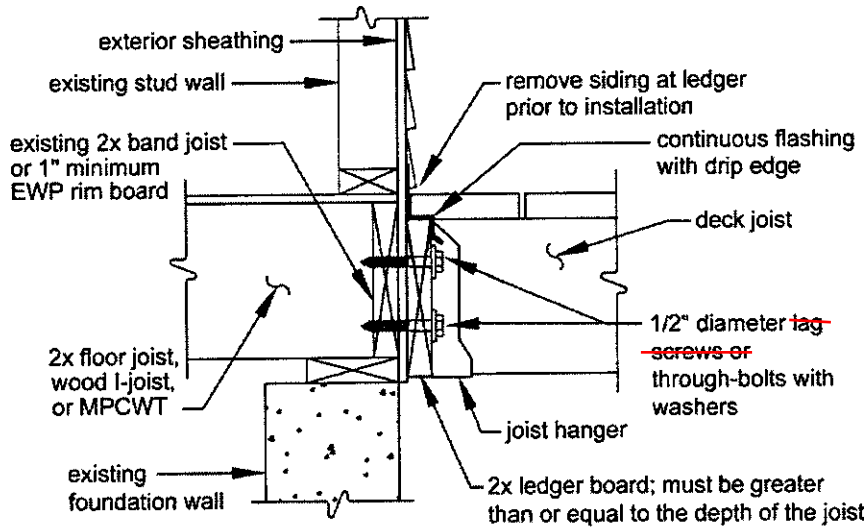

Figure 14: General Attachment of Ledger Board to Band Board



Through bolts, 1/2" diameter spaced in accordance with Table 5.

Figure 15: Attachment of Ledger Board to Foundation Wall (Concrete or Solid Masonry)

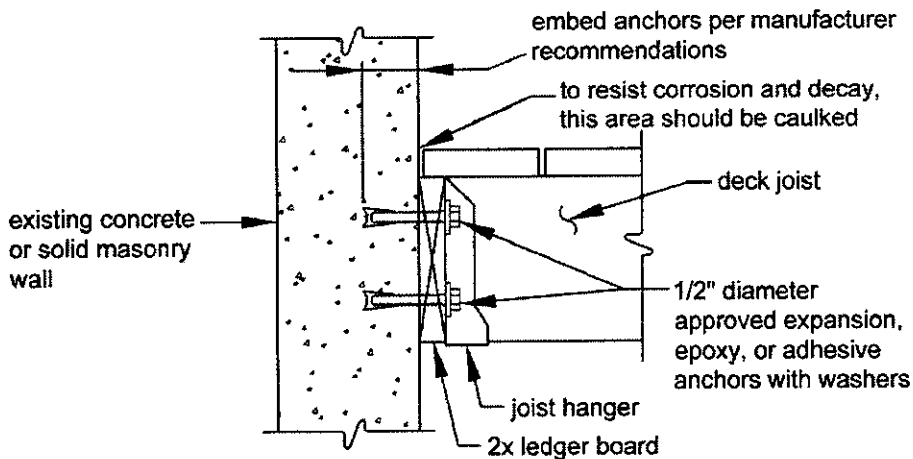
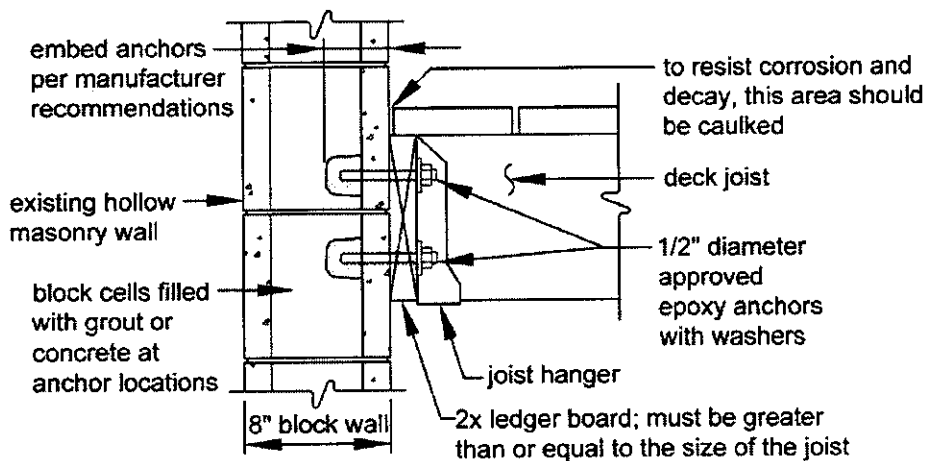

Figure 16: Attachment of Ledger Board to Foundation Wall (Hollow Masonry)



PROHIBITED LEDGER ATTACHMENTS

Attachments to exterior veneers (brick, masonry, stone) and to cantilevered floor overhangs or bay windows are prohibited (see Figures 17 and 18). In such cases the

deck shall be free-standing (see FREE-STANDING DECKS).

Figure 17: No Attachment to or Through Exterior Veneers (Brick, Masonry, Stone)

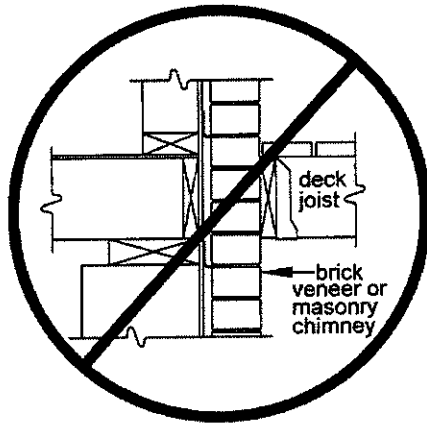
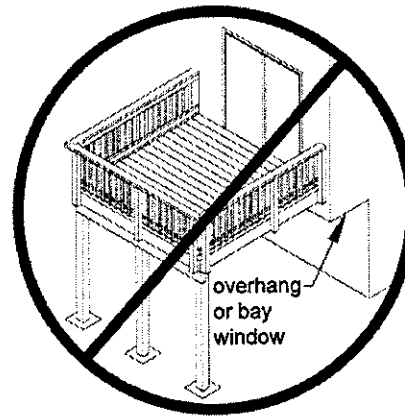

Figure 18: No Attachment to House Overhang



LEDGER BOARD FASTENERS

Deck ledger connection to band joist or rim board.

The connection between a deck ledger and a 2-inch nominal band joist (1-1/2" actual) or EWP rim board bearing on a sill plate or wall plate shall be constructed

with 1/2" lag screws or bolts with washers per Table 5 and Figure 19 (see MINIMUM REQUIREMENTS). Only those fasteners noted below are permitted. LEAD ANCHORS ARE PROHIBITED.

Table 5. Fastener Spacing for a Southern Pine, Douglas Fir-Larch, or Hem-Fir Deck Ledger and a 2-inch Nominal Solid-Sawn Spruce-Pine-Fir^{7,9} Band Joist or EWP Rim Board⁶
(Deck Live Load = 40 psf, Deck Dead Load = 10 psf)^{3,6}

| Joist Span | Rim Board or Band Joist | 6'-0" and less | 6'-1" to 8'-0" | 8'-1" to 10'-0" | 10'-1" to 12'-0" | 12'-1" to 14'-0" | 14'-1" to 16'-0" | 16'-1" to 18'-0" |
|--|------------------------------|---|----------------|-----------------|------------------|------------------|------------------|------------------|
| | | On-Center Spacing of Fasteners ^{4,5} | | | | | | |
| 1/2" diameter lag screw with 15/32" maximum sheathing¹ | 1" EWP ⁶ | 24" | 18" | 14" | 12" | 10" | 9" | 8" |
| | 1-1/8" EWP ⁶ | 20" | 21" | 16" | 14" | 12" | 10" | 9" |
| | 1-1/2" Lumber ^{7,9} | 30" | 23" | 18" | 15" | 13" | 11" | 10" |
| 1/2" diameter bolt with 15/32" maximum sheathing | 1" EWP ⁶ | 24" | 18" | 14" | 12" | 10" | 9" | 8" |
| | 1-1/8" EWP ⁶ | 28" | 21" | 16" | 14" | 12" | 10" | 9" |
| | 1-1/2" Lumber ^{7,9} | 36" | 36" | 34" | 29" | 24" | 21" | 19" |
| 1/2" diameter bolt with 15/32" maximum sheathing and 1/2" stacked washers ^{2,8} | 1" EWP ⁶ | 24" | 18" | 14" | 12" | 10" | 9" | 8" |
| | 1-1/8" EWP ⁶ | 28" | 21" | 16" | 14" | 12" | 10" | 9" |
| | 1-1/2" Lumber ^{7,9} | 36" | 36" | 29" | 24" | 21" | 18" | 16" |

~~1 The tip of the lag screw shall fully extend beyond the inside face of the band joist.~~
 2 The maximum gap between the face of the ledger board and face of the wall sheathing shall be 1/2".
 3 Ledgers shall be flashed or caulked to prevent water from contacting the house band joist (see Figures 14, 15, and 16).
 4 ~~Lag screws and bolts shall be staggered per Figure 19.~~
 5 Deck ledgers shall be minimum 2x8 pressure-preservative-treated No.2 grade lumber, or other approved materials as established by standard engineering practice.
 6 When solid-sawn pressure-preservative-treated deck ledgers are attached to engineered wood products (oriented strand board or structural composite lumber including laminated veneer lumber), the ledger attachment shall be designed in accordance with accepted engineering practice. Tabulated values based on 300 lb and 350 lb for 1" and 1-1/8" EWP rim board, respectively.
 7 A minimum 1"x9 1/2" Douglas fir-larch laminated veneer lumber rim board shall be permitted in lieu of the 2" nominal band joist.
 8 Wood structural panel sheathing, gypsum board sheathing, or foam sheathing not exceeding one inch thickness shall be permitted. The maximum distance between the face of the ledger board and the face of the band joist shall be one inch.
 9 Fastener spacing also applies to southern pine, Douglas fir-larch, and hem-fir band joists.

Placement of lag screws or bolts in deck ledgers

The lag screws or bolts shall be placed two inches from the bottom or top of the deck ledgers and between two and five inches from the ends. The lag screws or bolts

shall be staggered from the top to the bottom along the horizontal run of the deck ledger (see Figure 19). Proper installation of lag screws or bolts shall be verified by the building official.

Figure 19: Ledger Board Fastener Spacing and Clearances

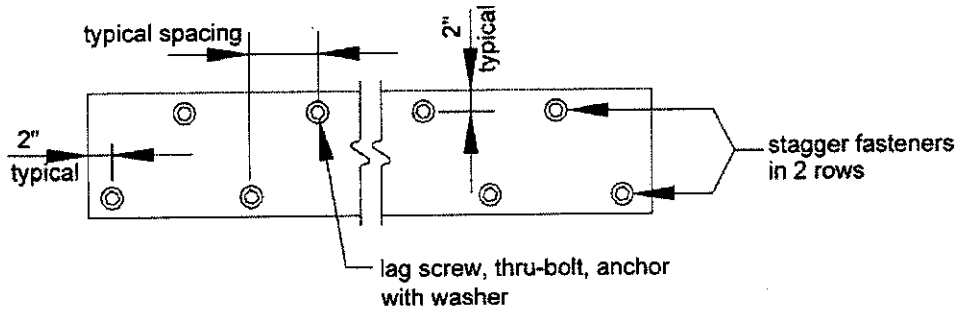

Thru-Bolts

Thru-bolts shall have a minimum diameter of 1/2". Pilot holes for thru-bolts shall be 7/32" to 9/16" in diameter. Thru-bolts require washers at the bolt head and nut.

diameter of 1/2". Minimum embedment length shall be per the manufacturer's recommendations. All anchors must have washers.

Expansion and Adhesive Anchors

Use approved expansion or adhesive anchors when attaching a ledger board to a concrete or solid masonry wall as shown in Figure 15 or a hollow masonry wall with a grouted cell as shown in Figure 16. Expansion and adhesive anchor bolts shall have a minimum

~~Lag Screws~~

~~Lag screws shall have a minimum diameter of 1/2" (see MINIMUM REQUIREMENTS). Lag screws may be used only when the field conditions conform to those shown in Figure 14. See Figure 20 for lag screw length and shank requirements. All lag screws shall be installed with washers.~~

Figure 20: Lag Screw Requirements

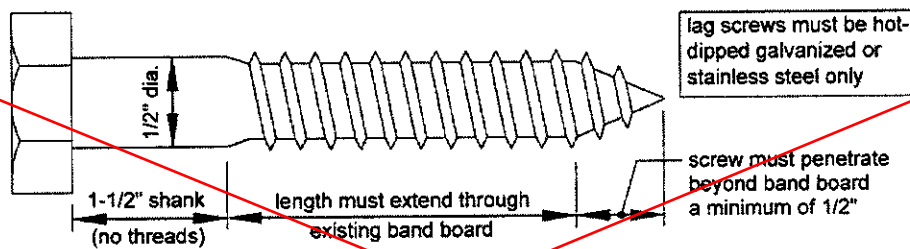

Lag screw installation requirements: Each lag screw shall have pilot holes drilled as follows. 1) Drill a 1/2" diameter hole in the ledger board, 2) Drill a 5/16" diameter hole into the band board of the existing house. **DO NOT DRILL A 1/2" DIAMETER HOLE INTO THE BAND BOARD.**

The threaded portion of the lag screw shall be inserted into the pilot hole by turning. **DO NOT DRIVE LAG SCREWS WITH A HAMMER.** Use soap or a wood-compatible lubricant as required to facilitate tightening. Each lag screw shall be thoroughly tightened (snug but not over-tightened to avoid wood damage).

FREE-STANDING DECKS

Decks which are free-standing do not utilize the exterior wall of the existing house to support vertical loads; instead, an additional beam with posts is provided at or within L/4 of the existing house. THE ASSOCIATED DECK POST FOOTINGS SHALL BE PLACED AT

THE SAME ELEVATION AS THE EXISTING HOUSE FOOTING (see Figure 2 and Figure 12). For houses with basements, a cylindrical footing (caisson) is recommended to minimize required excavation at the basement wall. Beam size is determined by Table 3.

Figure 21: Free-Standing Deck

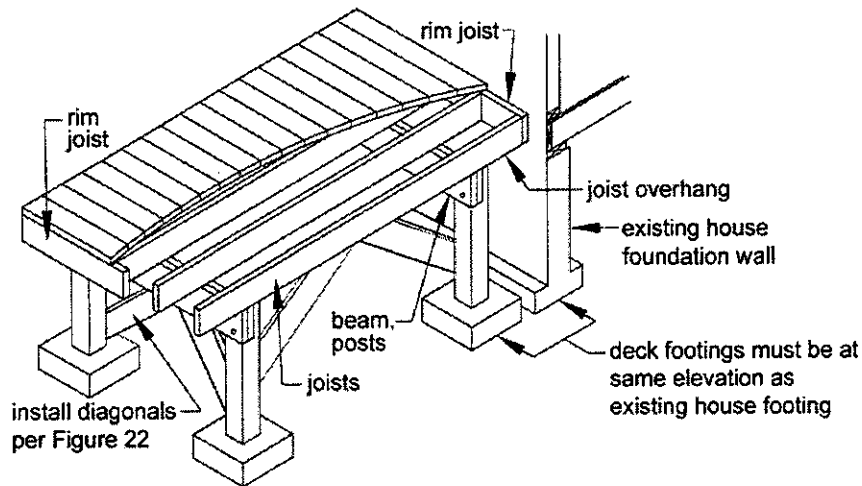

DECK STABILITY

Decks greater than 2 feet above grade shall be provided with diagonal bracing or be attached to the exterior wall of the house.

Figure 22: Diagonal Bracing Requirements

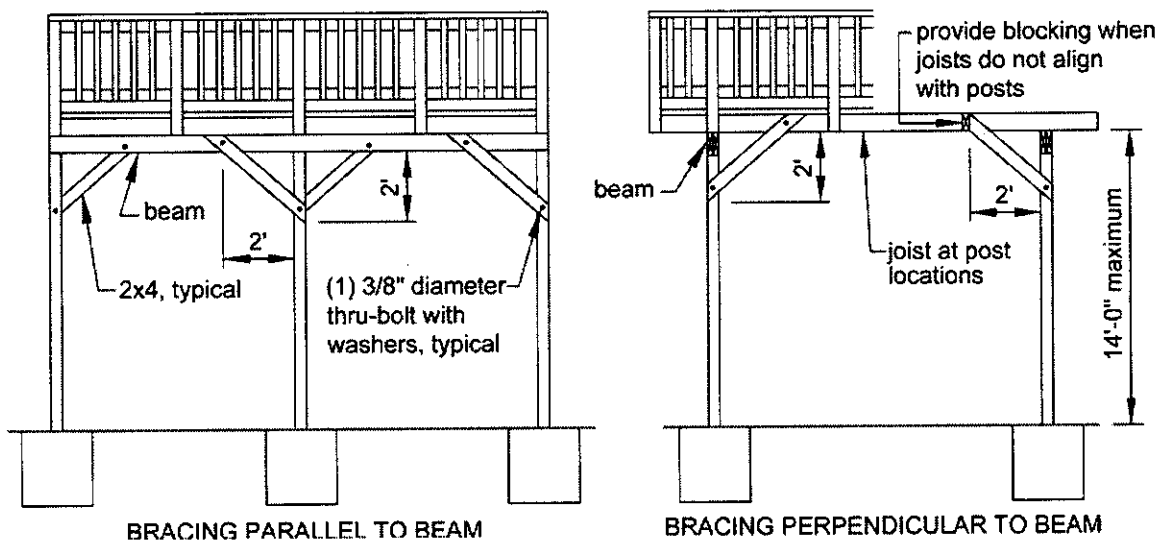

Diagonal Bracing: Provide diagonal bracing both parallel and perpendicular to the beam at each post as shown in Figure 22. When parallel to the beam, the bracing shall be bolted to the post at one end and beam at the other. When perpendicular to the beam, the bracing shall be bolted to the post at one end and a joist or blocking between joists at the other. When a joist does not align with the bracing location, provide blocking between the next adjacent joists.

Attachment to House: Attach the deck rim joist to the existing house exterior wall as shown in Figure 23. The

wall must be sheathed with minimum $\frac{3}{8}$ " wood structural panel sheathing. Use lag screws or thru-bolts when fastening to an existing band joist or wall stud; use expansion anchors or epoxy anchors when fastening to concrete or masonry. **DO NOT ATTACH TO BRICK VENEERS. VERIFY THIS CONDITION IN THE FIELD PRIOR TO UTILIZING THIS METHOD.** Fasteners shall be 16" on center and staggered in 2 rows. Flashing over the rim joist is required and must be installed in accordance with the flashing provisions in the LEDGER ATTACHMENT REQUIREMENTS.

Figure 23: Attachment of Free-Standing Deck to House for Lateral Support

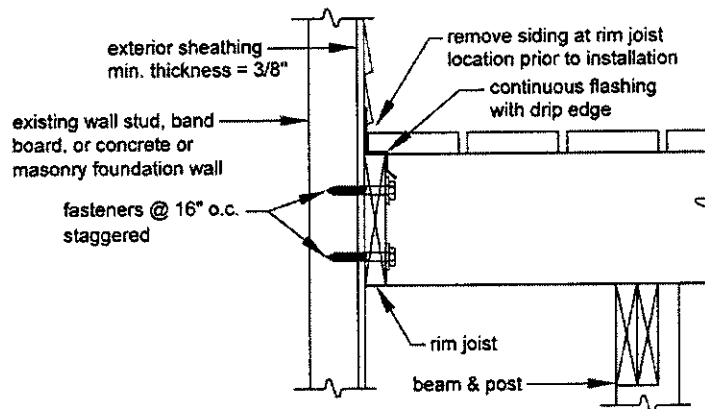

GUARD REQUIREMENTS [R312]

All decks greater than 30" above grade are required to have a guard as shown in Figure 24. If a guard is installed when one is not required, it must meet these requirements. Guard systems not meeting these requirements may be used when approved by the authority having jurisdiction.

Figure 24: Typical Guard Detail

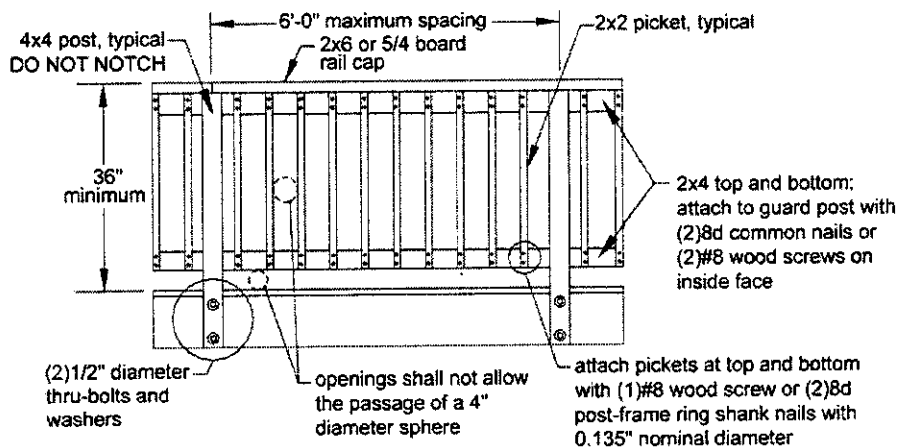

GUARD POST ATTACHMENTS

Deck guard posts shall be a minimum 4x4 (nominal) No.2 or higher grade (for species listed in Table 1) or with an adjusted bending design value not less than 1,050 psi.

GUARD POST TO OUTSIDE-JOIST: Guard posts for guards which run parallel to the deck joists shall be attached to the outside-joist per Figure 25.

Figure 25: Guard Post to Outside Joist Detail

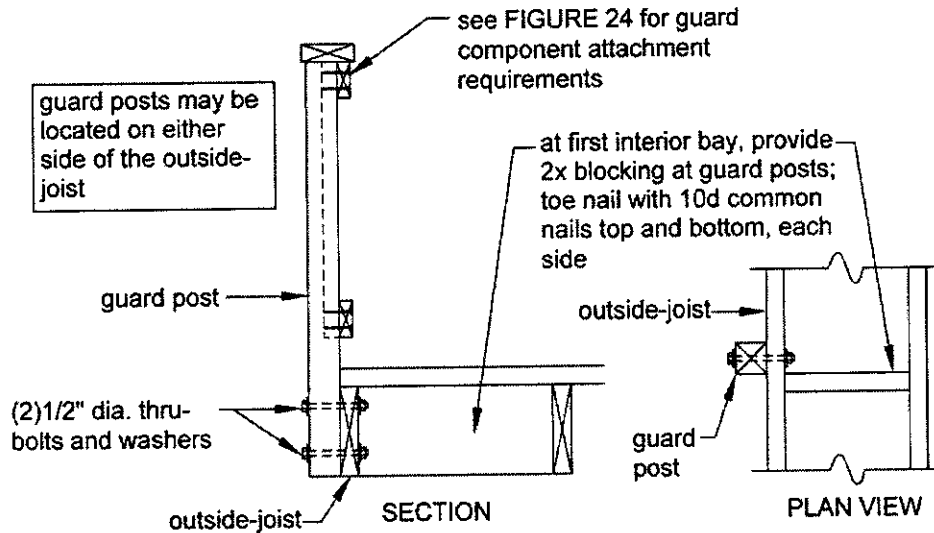

GUARD POST TO RIM JOIST: Guard posts for guards that run perpendicular to the deck joists shall be attached to the rim joist in accordance with Figure 26. As shown in Figure 26, hold-down anchors must be installed to attach the guard post and rim joist to the

deck joists. There shall be a minimum of two bolts at the hold-down anchors' attachment to the joist. Only hold-down anchor models meeting these minimum requirements shall be used.

Figure 26: Guard Post to Rim Joist Detail

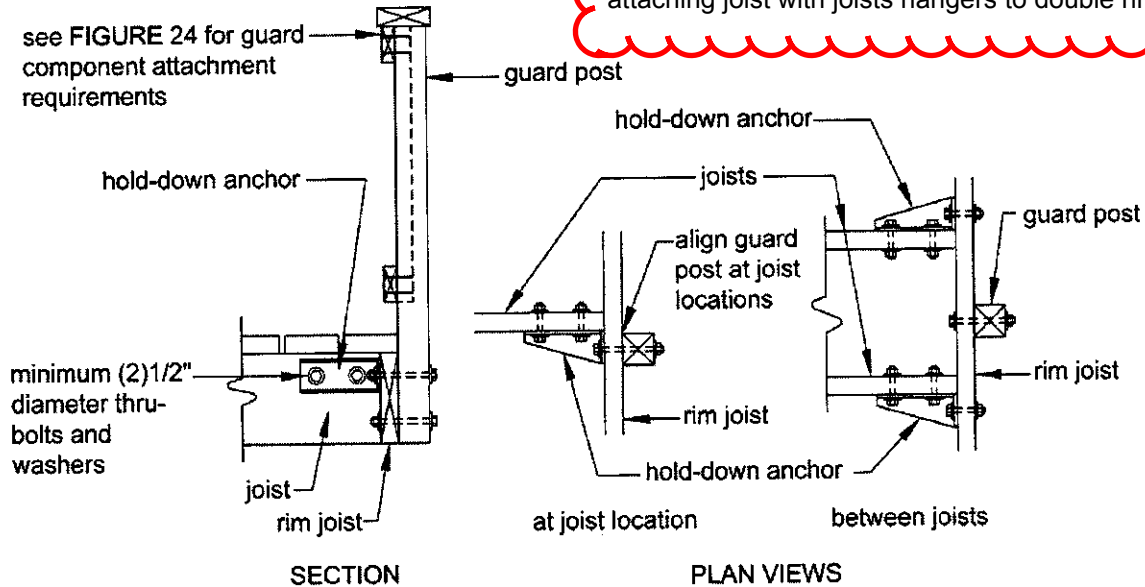

The use of hold down anchors is seen as an option to attaching joist with joists hangers to double rim board

STAIR REQUIREMENTS [R311.5]

Stairs, stair stringers, and stair guards shall meet the requirements shown in Figure 27 through Figure 34 except where amended by the local jurisdiction. All stringers shall be a minimum of 2x12. Stair stringers shall not span more than the dimensions shown in Figure

28. If the stringer span exceeds these dimensions, then an intermediate landing will be required. A flight of stairs shall not have a vertical rise larger than 12 feet between floor levels or landings. All intermediate stair landings must be designed and constructed as a free-standing deck using the details in this package.

Figure 27: Tread and Riser Detail

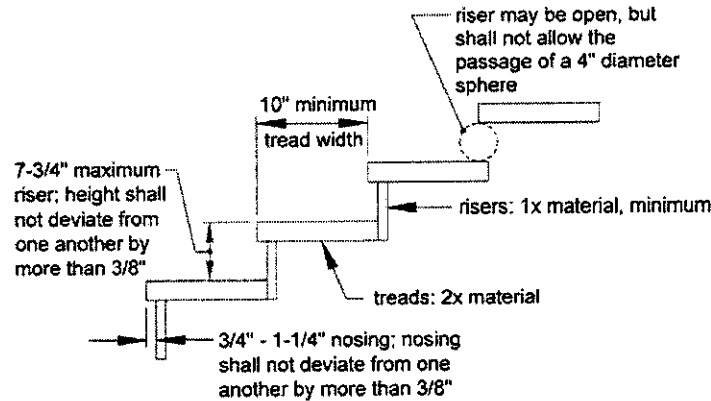

Figure 28: Stair Stringer Requirements

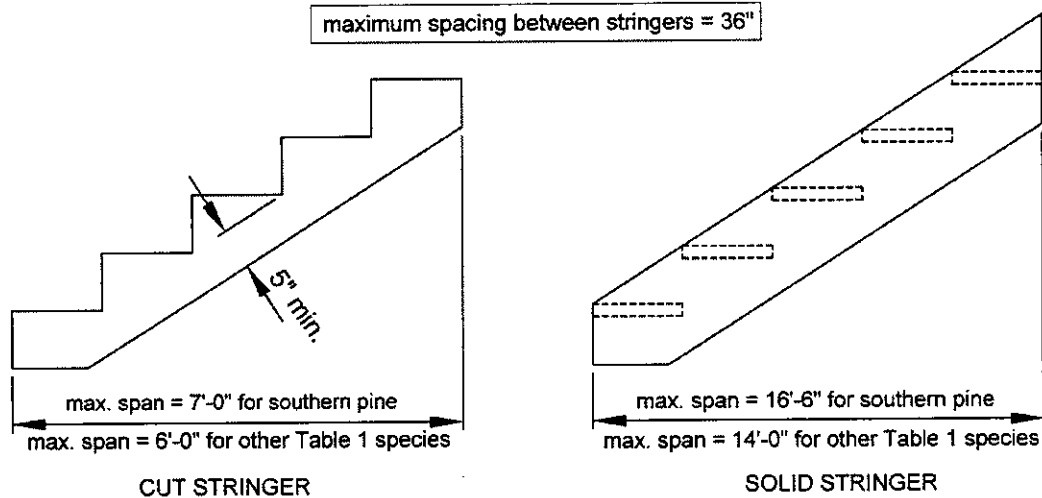

Figure 29: Tread Connection Requirements

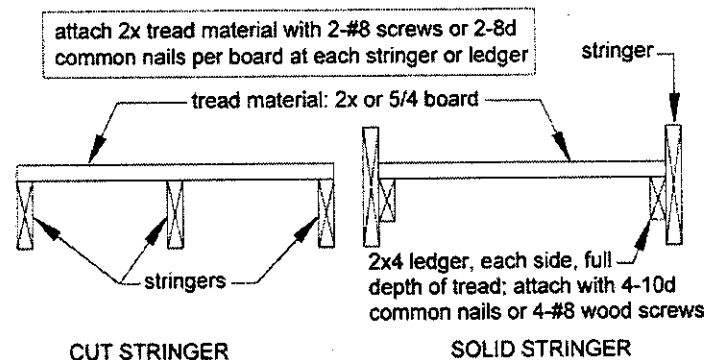

Figure 30: Stair Guard Requirements

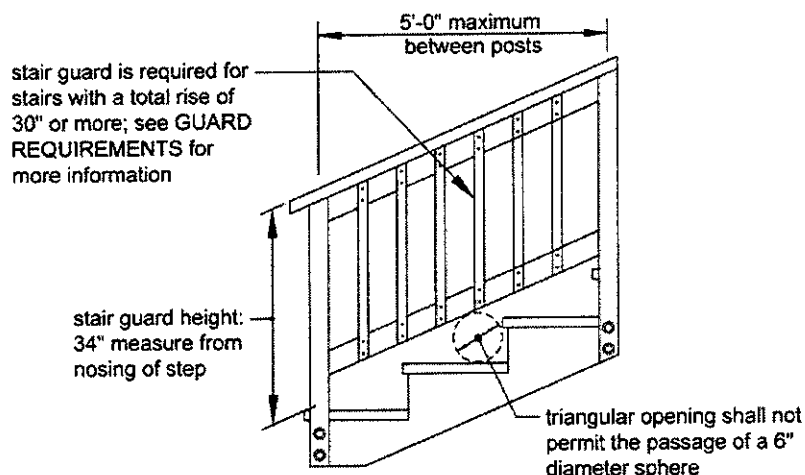
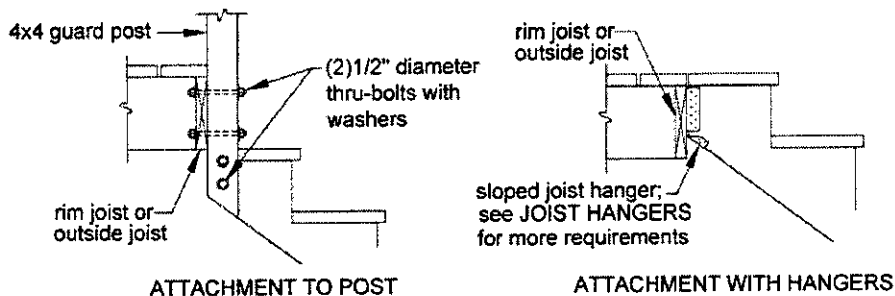

Figure 31: Stair Stringer Attachment Detail



STAIR HANDRAIL REQUIREMENTS

All stairs with 4 or more risers shall have a handrail on one side (see Figure 32). The handrail height measured vertically from the sloped plane adjoining the tread nosing shall be not less than 34 inches and not more than 38 inches (see Figure 30). Handrails shall be graspable and shall be composed of decay-resistant and/or corrosion resistant material. The hand grip portion, if circular, shall be between 1 1/4" and 2" in diameter.

Shapes other than circular shall have a perimeter dimension of at least 4" and not greater than 6 1/4" with a maximum cross sectional dimension of 2 1/4". All shapes shall have a smooth surface with no sharp corners. Handrails shall run continuously from a point directly over the lowest riser to a point directly over the highest riser and shall return to the guard at each end (see Figure 33). Handrails may be interrupted by guard posts only at a turn in the stair.

Figure 32: Handrail Requirements

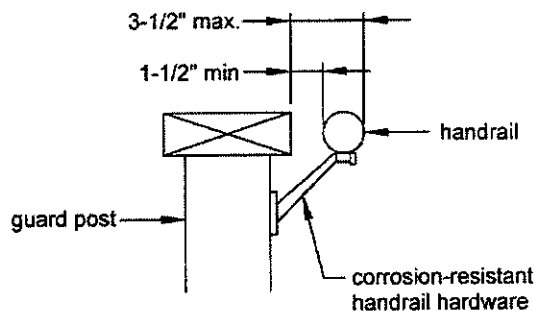

STAIR FOOTING REQUIREMENTS

Where the stairway meets grade, attach the stringers to the stair guard posts as shown in Figure 34. Posts shall bear on footings. All footings shall bear on solid ground and shall be placed at least 12 inches below the undisturbed ground surface or below the frost line,

whichever is deeper (see Figure 34). Stringers shall not bear on new or existing concrete pads or patios that are not founded below this depth. When guards are not required (see **GUARD REQUIREMENTS**), posts may terminate below the bottom tread elevation.

Figure 33: Miscellaneous Stair Requirements

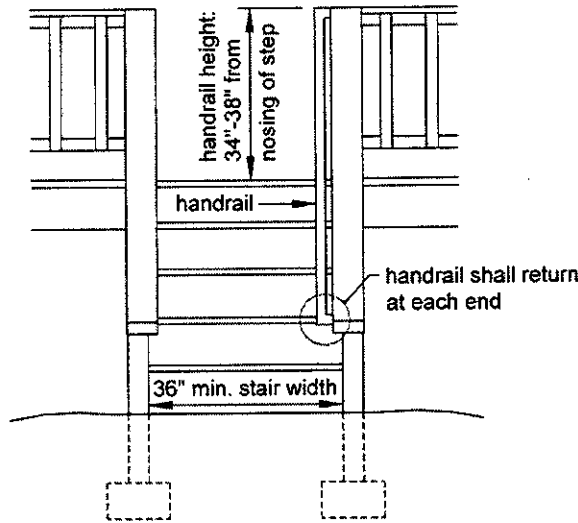
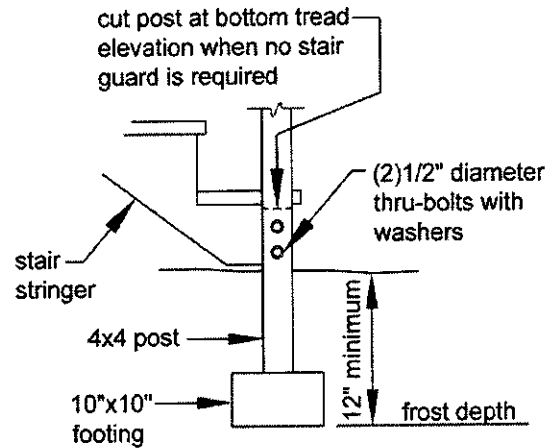

Figure 34: Stair Footing Detail



STAIR LIGHTING REQUIREMENTS

Stairways shall have a light source located at the top landing such that all stairs and landings are illuminated [R303.6]. The light switch shall be operated from inside the house. However, motion detected or timed switches are acceptable.

FRAMING AT CHIMNEY OR BAY WINDOW

All members at a chimney or bay window shall be framed in accordance with Figure 35. Headers may span a maximum of 6'-0". When a chimney or bay window is wider than 6'-0", one or more 6x6 posts may be added to reduce header spans to less than 6'-0". In such cases, the post footing must meet the requirements in the **FOOTINGS** section. Headers with a span length greater than 6'-0" require a plan submission.

Figure 35: Detail for Framing Around a Chimney or Bay Window

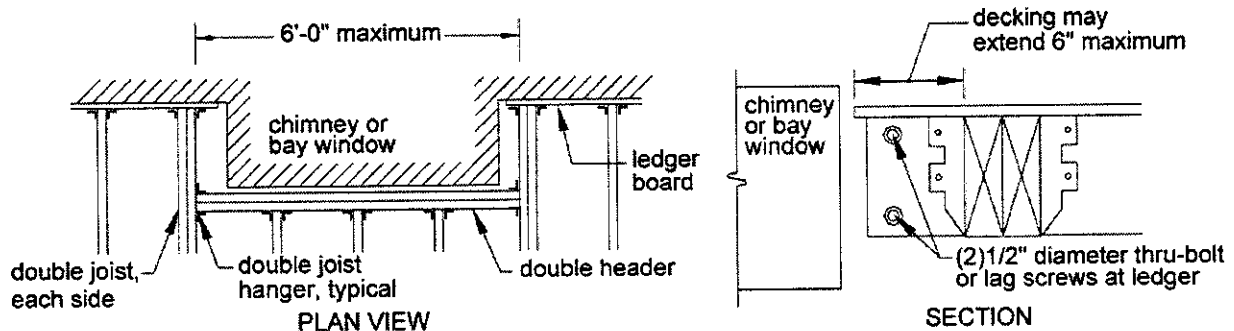



A F & P A ®

**AMERICAN
WOOD
COUNCIL***Engineered and Traditional Wood Products*

It is intended that this document be used in conjunction with accurate fabrication and adequate supervision of construction. While every effort has been made to insure the accuracy of the information presented, the American Forest & Paper Association and its members do not assume responsibility for errors or omissions in the document, nor for designs, plans, or construction prepared from it. Those using this document assume all liability arising from its use.

Copyright © 2007
American Forest & Paper Association, Inc.

12-07

